

Analysis of Measurement-based Quantum Network Coding Protocol over Repeater Networks under Noisy Conditions

Takaaki Matsuo¹, Takahiko Satoh¹, Shota Nagayama, Rodney Van Meter¹
¹Keio University

Abstract: We have developed a new network coding protocol for repeater networks based on measurement-based quantum computing (MQNC), and studied its behavior using Monte-Carlo simulation under noisy conditions, comparing it with buffer-space multiplexing using step-by-step and simultaneous entanglement swapping (ES and ES_p), and quantum network coding (QNC). For MQNC, we have found that the resulting entangled pairs' joint fidelity drops below 50% when the accuracy of local operations is under 98.9%, assuming that all initial resources across quantum repeaters have a fixed fidelity of 98%. Overall, our protocol showed substantially higher error tolerance compared to QNC and similar to ES but not as strong as ES_p.

1. Our protocol

Our protocol protocol, **measurement-based quantum network coding (MQNC)**, has achieved a **56.5% reduction of circuit depth** from QNC (see 2.2) by exploiting measurement-based quantum computing.

Measurement-based QNC for Repeater Networks (MQNC)

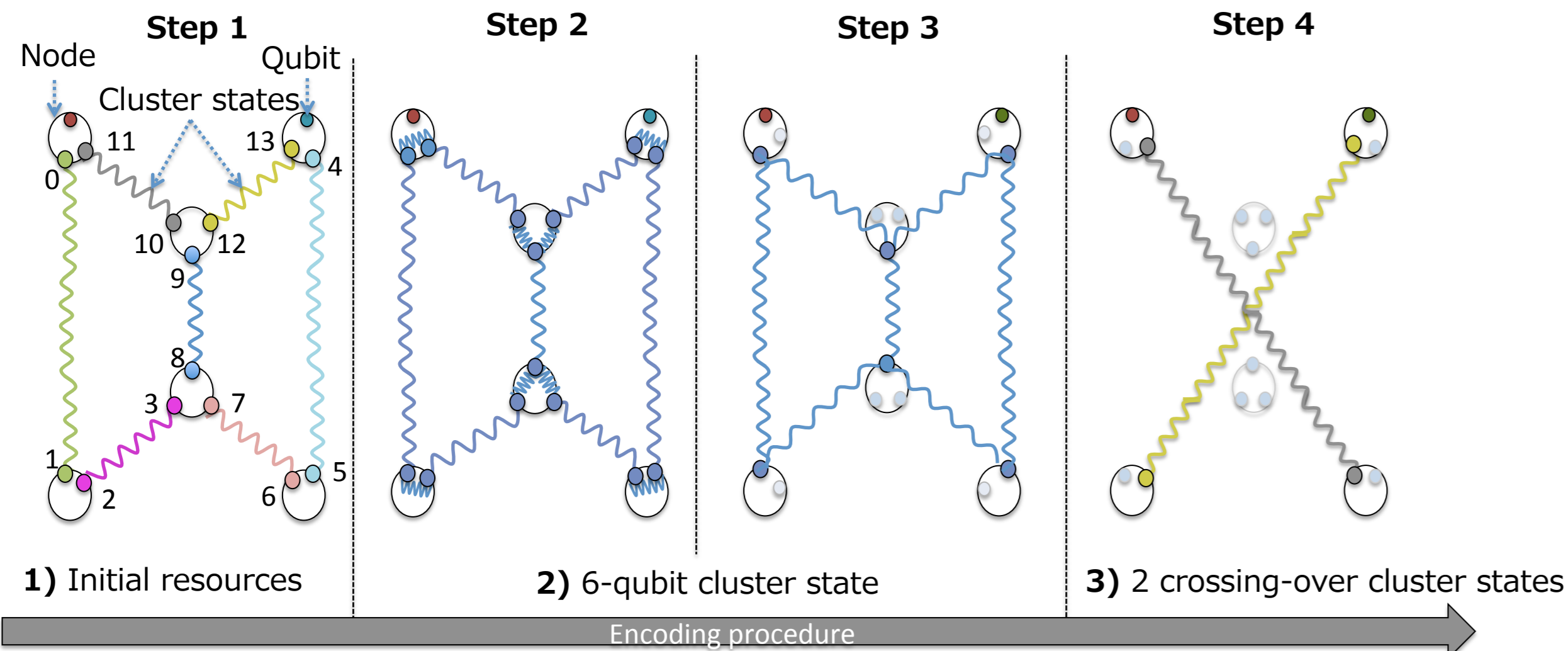

Rough Encoding Procedure:

- Step 1** – Initialize entangled resources across quantum repeaters
- Step 2** – Locally connect all qubits using CZ gate, and remove all unwanted qubits using Y measurements to shape a butterfly network
- Step 3** – Apply X measurements to the qubits at the bottleneck to create 2 crossing-over entanglements

Circuit for MQNC

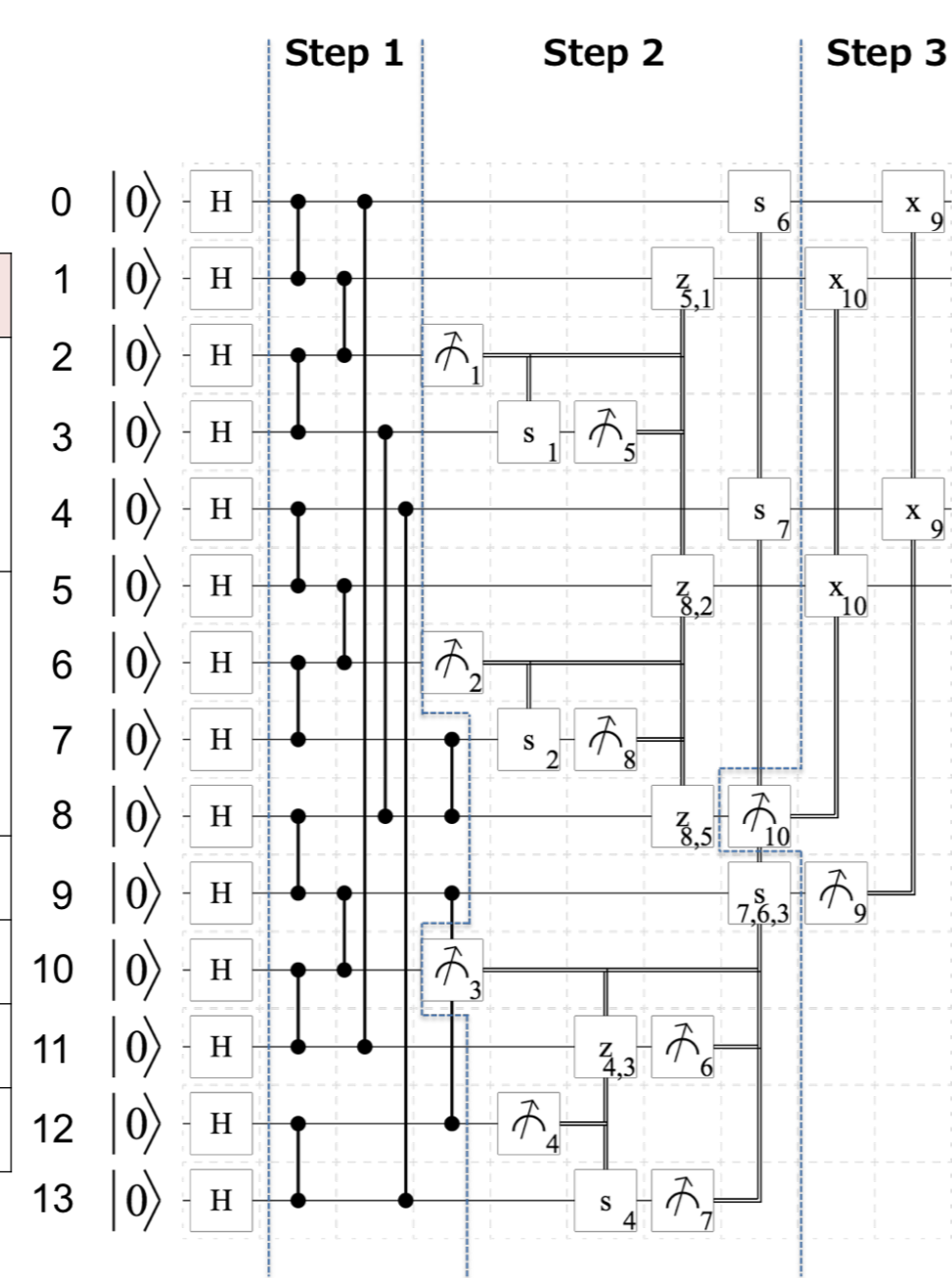

Characteristics of protocols

	MQNC	QNC	ES	ES_p
# of qubits	14	14	12	12
(# of entanglements)	(7)	(7)	(6)	(6)
# of single qubit gates (Byproduct operations)	14 (14)	16 (11)	12 (8)	8 (4)
# of two qubit gates	8	8	4	4
# of measurements	10	10	8	4
Circuit depth	10	23	12	6
KQ	140	322	144	72

3. Main Result

Our protocol is evaluated under noisy conditions using Monte-Carlo simulation with various error sources (**initial resource error**, **memory error**, **gate error** and **measurement error**), and compared with quantum network coding (QNC) and buffer-space multiplexing using entanglement swapping (BSM).

Error propagation throughout the each circuit is tracked classically

Impact of initial resource error to output joint fidelity

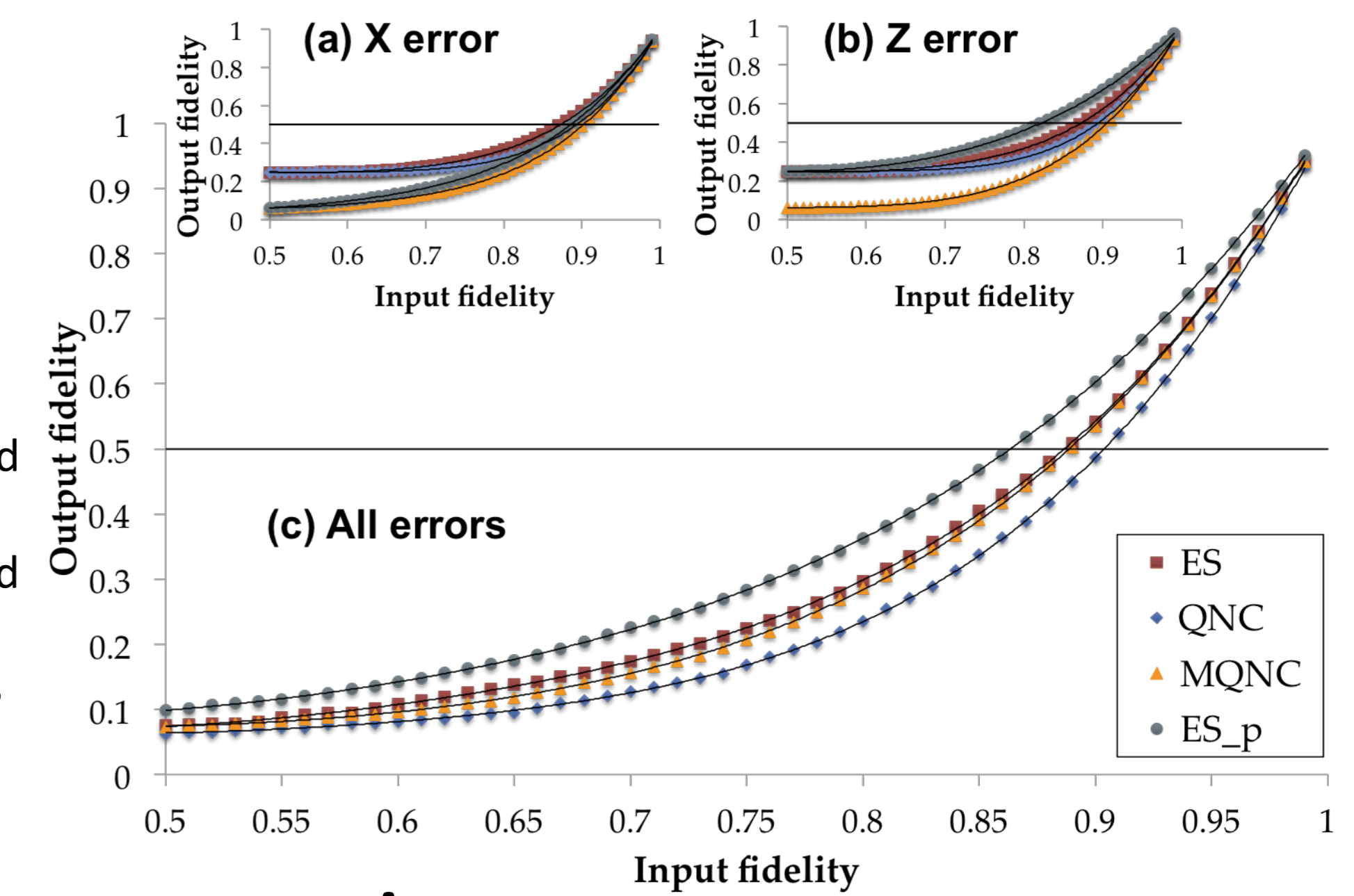

Errors on initial resources

Parameter settings:

- Input (Initial resource) fidelity: 50% ~ 99%
- Local Operation accuracy: 100%

Scenarios:

- Probabilistic X error present on the qubits labeled with odd numbers
- Probabilistic Z error present on the qubits labeled with odd numbers
- Probabilistic X, Z or Y errors present on all qubits

Errors on initial resources and gate operations

(initial resources, memories, single and two-qubit gates, measurements)

Parameter settings:

- Initial resource fidelity: 98%
- Local Operation accuracy: 98%~100%

Impact of local operation errors to output fidelity

Perfect memory with noisy gates

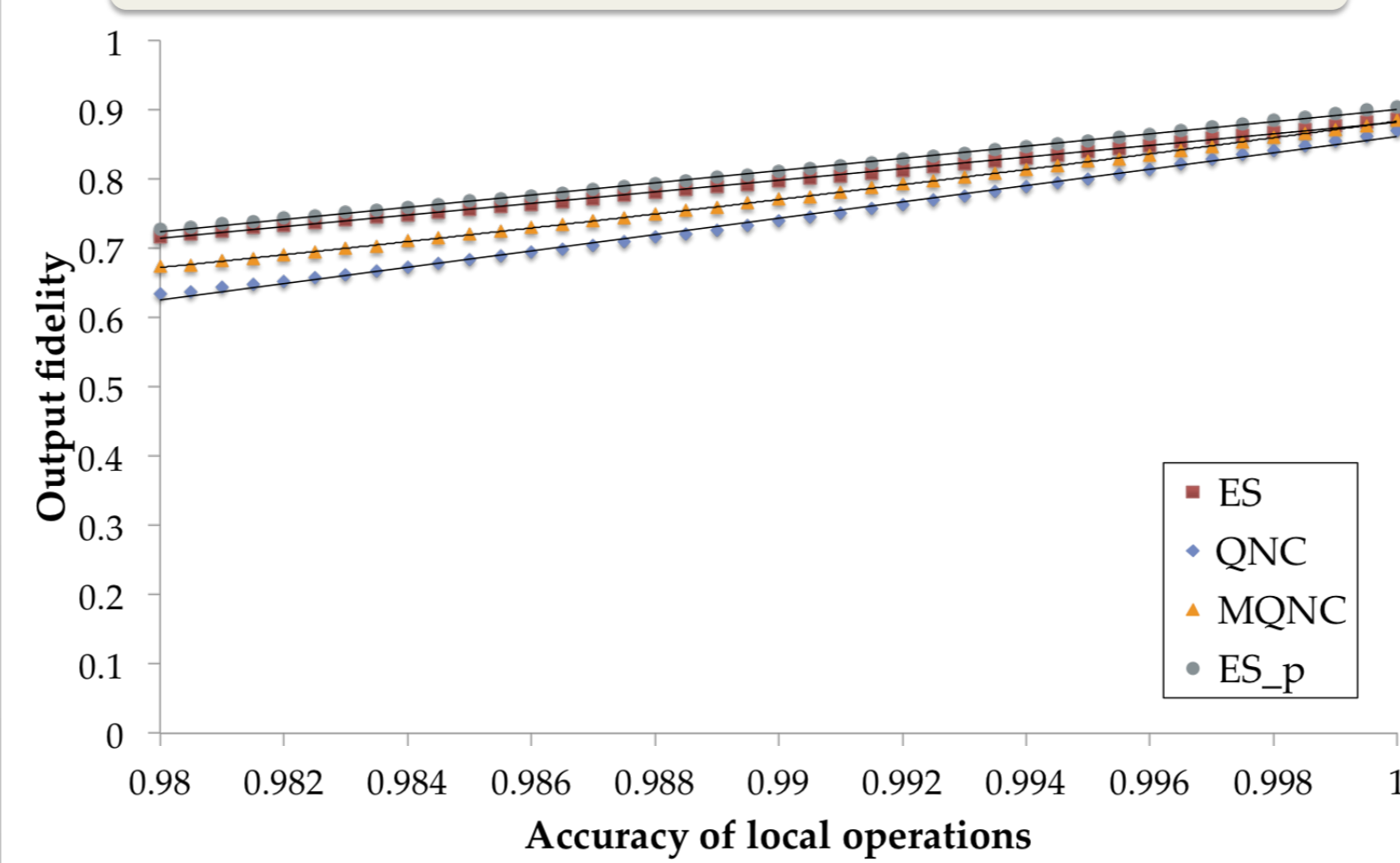

Impact of local operation errors to output fidelity

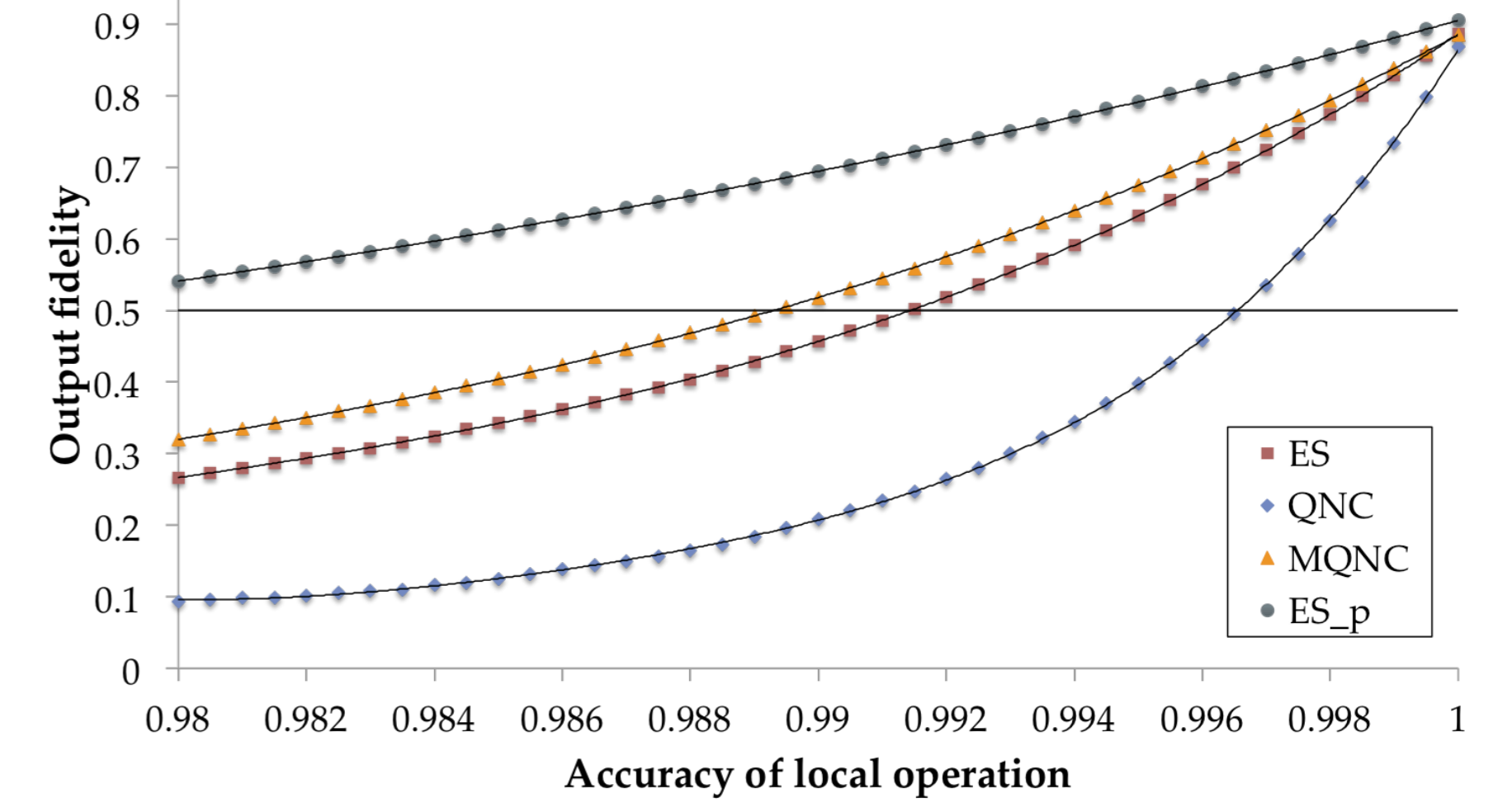

Errors distribution on one entangled output

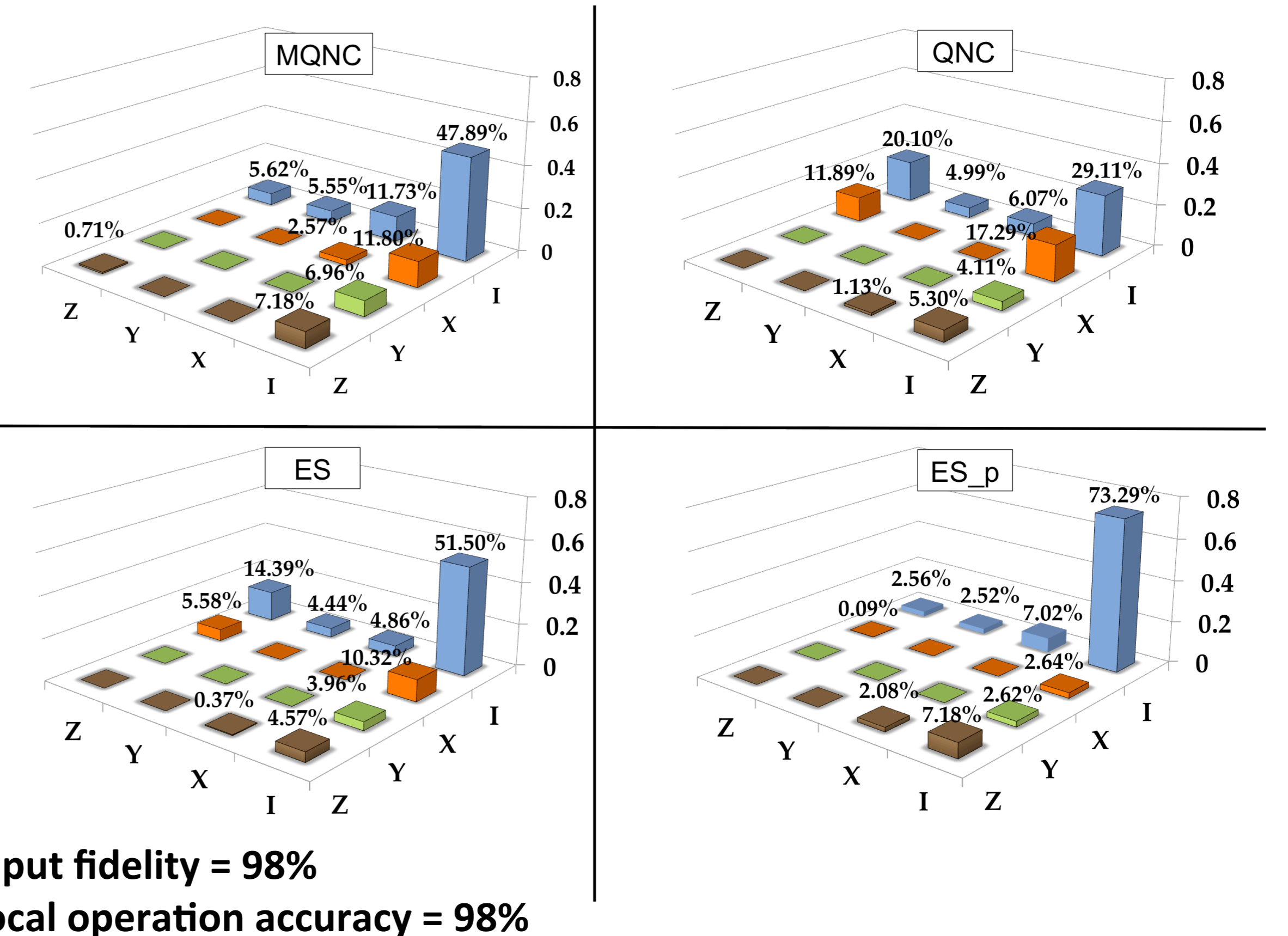

※When Input fidelity = 98%
Local operation accuracy = 98%

2. Background

Network coding is an important technique for alleviating bottlenecks in networks to improve the overall throughput.

2.1 Classical Network Coding

The task of network coding is to transmit the information bit X from S1 to t2, and Y from S2 to t1 simultaneously [1].

Classical network coding

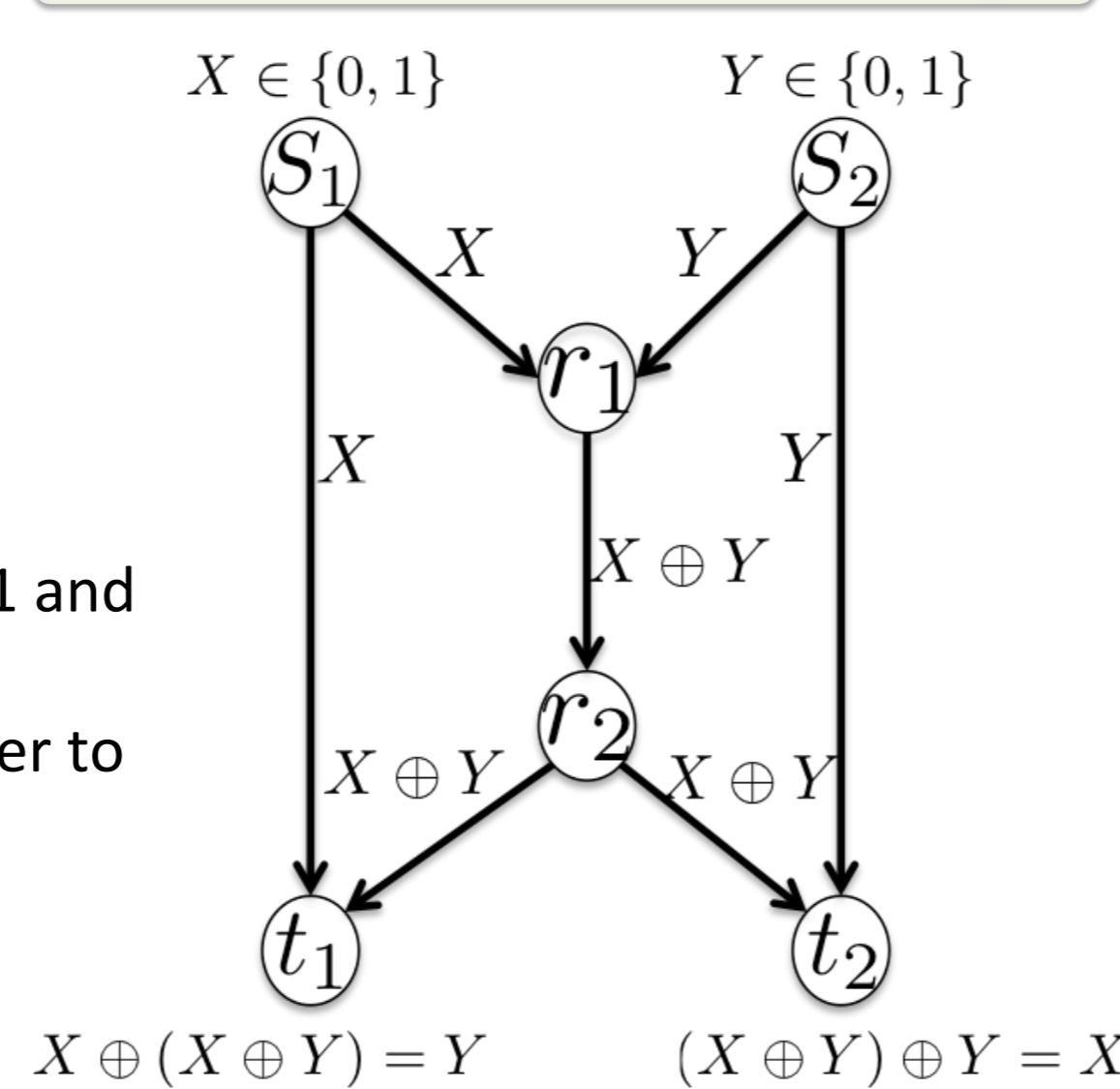

Encoding Procedure of Network Coding

- Input bits X, and Y prepared at S1 and S2 respectively
- Send X from S1 to t1 and r1, and Y from S2 to t2 and r1
- Apply XOR operation at the relay node r1 and send it to t1 and t2 via r2
- Apply XOR operation at the target nodes t1 and t2, in order to reconstruct the original information

2.2 Quantum Network Coding

Quantum Network Coding for Repeater Networks (QNC)

Recent studies of network coding have extended to quantum information [2-4].

QNC is a network coding technique for quantum communication over repeater networks. Its main role is to create two diagonally placed entanglements over a butterfly network [5, 6].

QNC circuit

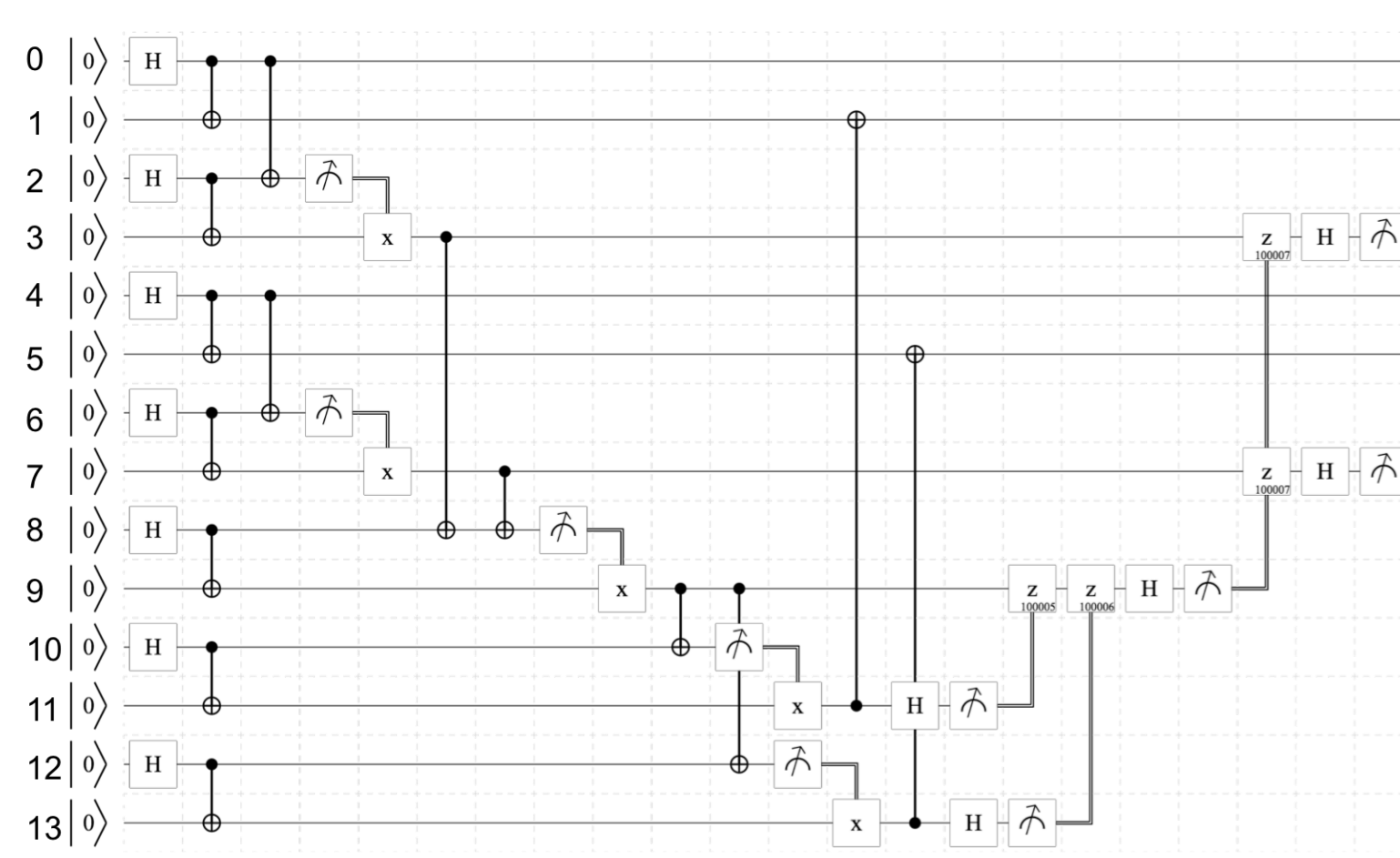

QNC on butterfly network

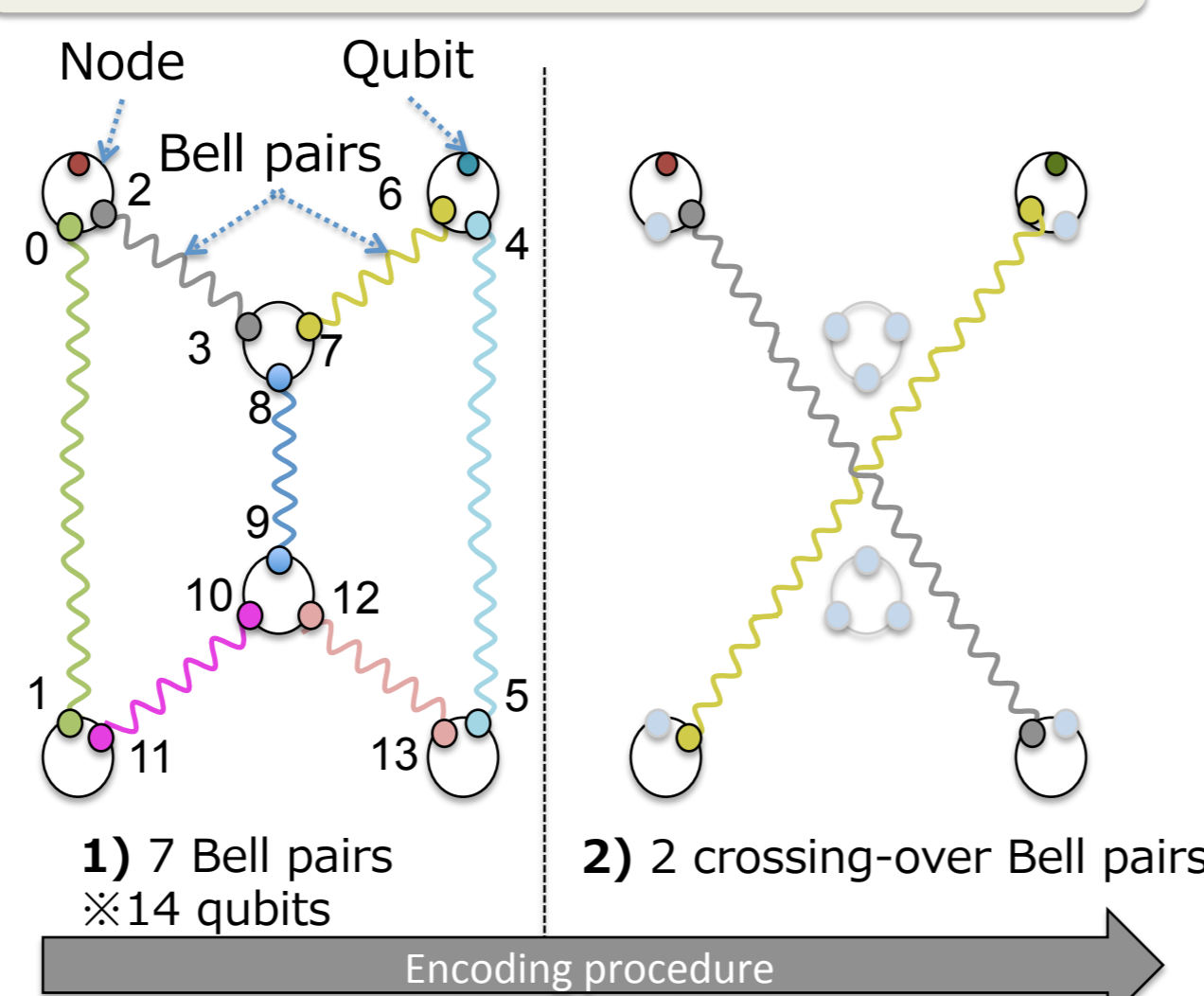

4. Conclusion

In general, we see that our protocol showed a substantial improvement of error tolerance compared to QNC. Depending on the situation, MQNC is slightly worse or better than ES. ES_p is in general stronger than other protocols, however, one should be reminded that ES and ES_p requires an extra cycle to complete the whole process. To conclude, MQNC is more practical than QNC, but the choice of MQNC or ES_p is still discussable. If network resources are abundant or if slower communication is permitted, ES_p may be more useful. In contrast, MQNC is more practical if higher communication speed is required or if resource contention is critical and needs to be resolved.

Acknowledgement

This work is supported by JSPS KAKENHI Grant Number 16H02812

References

- [1] Rudolf Ahlswede, Ning Cai, Shuoyen Robert Li and Raymond W. Yeung Network information flow IEEE Transactions on Information Theory 2000 Vol.46, no. 4, pp. 1204-1216
- [2] Masahito Hayashi Prior entanglement between senders enables perfect quantum network coding with modification Phys. Rev. A 2007 Vol. 76, p.040301
- [3] Hirotsada Kobayashi, Francois Le Gall, Harumichi Nishimura and Martin Roetteler General scheme for perfect quantum network coding with free classical communication. Lecture Notes in Computer Science p. 12 2009
- [4] Hirotsada Kobayashi, Francois Le Gall, Harumichi Nishimura, and Martin Roetteler in 36th International Colloquium on Automata Languages and Programming (2009) pp. 622633.
- [5] Takahiko Satoh, Francois Le Gall and Hiroshi Imai Quantum network coding for quantum repeaters Phys. Rev. A 2012 Vol. 86
- [6] Takahiko Satoh, Kaori Ishizaki, Shota Nagayama and Rodney Van Meter Analysis of Quantum Network Coding for Realistic Repeater Networks Phys. Rev. A 2016 Vol. 93, no. 3